

NOVA COMMERCIAL

Twin-Wall, Insulated
Stainless Steel
Multi-Fuel
Chimney Systems

Suitable for condensing and
positive pressure applications

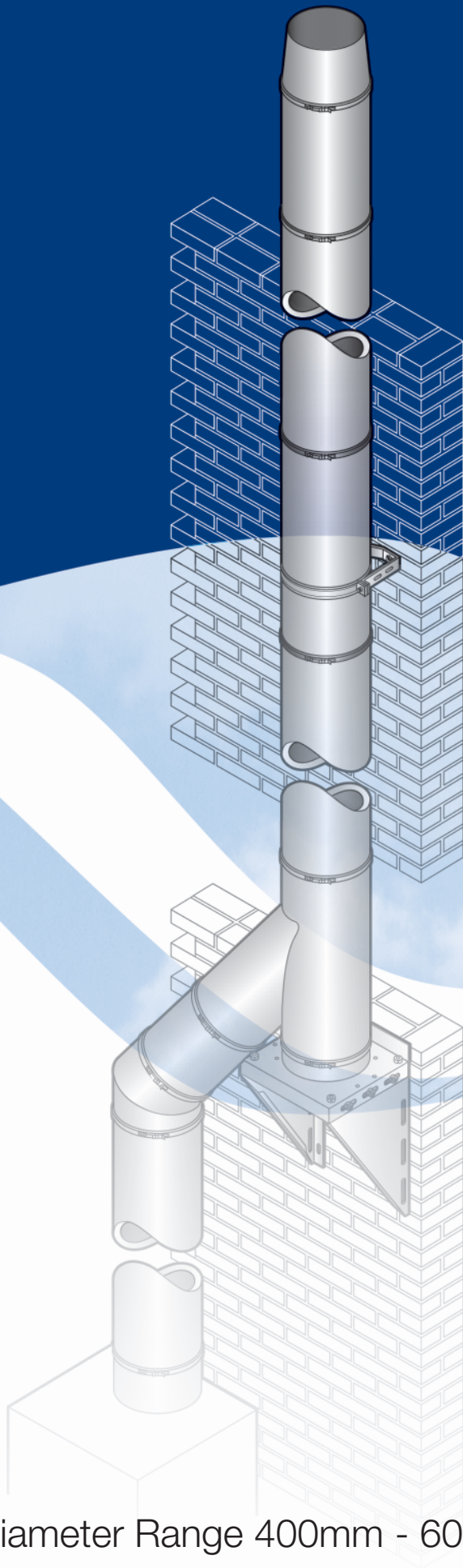

Diameter Range 400mm - 600mm

flues & chimneys
Confidence In Quality

The NOVA COMMERCIAL chimney system is specifically designed to meet the demands of the latest high efficiency heating appliances as well as the traditional gas and oil fired combustion equipment, offering a one solution product for today's market.

Introduction

Nova Commercial is an extension of the standard Nova product covering commercial diameters from 400mm to 600mm internal diameter. Nova Commercial is designed to meet the demands of the latest fully condensing and conventional boiler plant, while offering the traditional flexibility of a pre-fabricated chimney system. With its unique multi-barb twist-lock jointing system, Nova Commercial offers a superior joint allowing up to 2.5 metres unsupported height above the last support as well as a fast and efficient jointing method to speed up installation and therefore reduce associated labour time.

Description

Nova Commercial is a pre-fabricated, factory made twin-wall, insulated stainless steel chimney system. Each chimney element is fabricated with a fully welded 0.6mm 316L (1.4404:X2CrNiMo 17-12-2) stainless steel inner liner and a grade 304 (1.4301:X5CrNi 18-10) outer case. The 25mm annulus between the two walls is insulated with a high thermal performance pressure injected mineral fibre to a mean density of 250Kg/m³, offering rapid draught stabilisation while limiting thermal losses to the environment. The joint is made with a multi-barb twist lock coupler, ensuring a fast build time with reduced labour costs.

Condensate and pressure resistance if the application demands are undertaken by an elastomer seal positioned around the circumference of the inner liner, offering a pressure and leakage performance of P1 as defined under BS EN 1856-1.

Each joint once engaged is then fitted with a quick fit heavy duty Locking Band, offering additional strength to the joint whilst maintaining an aesthetic appearance.

Application

Nova Commercial offers five additional sizes to the standard Nova range covering 400, 450, 500, 550 and 600mm internal diameter. Applications include conventional oil and gas fired heating appliances, biofuels, as well as semi and fully condensing appliances. Where used on chimneys designed to operate under natural or zero draught condition on conventional heating appliances a maximum continuous flue gas temperature of up to 450°C can be maintained. Where the chimney design requires positive pressure and condensate resistance, Nova Commercial can be fitted with superior corrosion resistant EPDM elastomer seals. The seals facilitate a pressure capability of up to 200Pa at a permissible leakage of less than 0.006 l.s⁻¹.m⁻² as defined under BS EN 1856-1, at a maximum flue gas temperature of up to 120°C. Nova Commercial also has a two hour fire resistance in accordance with the stability and integrity criteria of BS 476: Part 20 for duct type B.

Quality / Approvals

Nova Commercial is manufactured and approved to BS EN 1856-1 and has been tested to BS EN 1859 to the performance designations as defined in Table 1.

All components are manufactured under a Quality Assurance Scheme, certificate No. FM01079, administered by British Standards in accordance with BS EN 9001:2000. In addition, SFL operates a Factory Production Control System as required under the Constructions Products Directive 93/68/EEC for products manufactured to BS EN 1856-1/2.



Table 1 - Nova Product Designation To BS EN 1856-1

NOVA	EN 1856-1	T450	N1	D	V2	L50060	O(50)
NOVA (S)	EN 1856-1	T120	P1	W	V2	L50060	O(50)

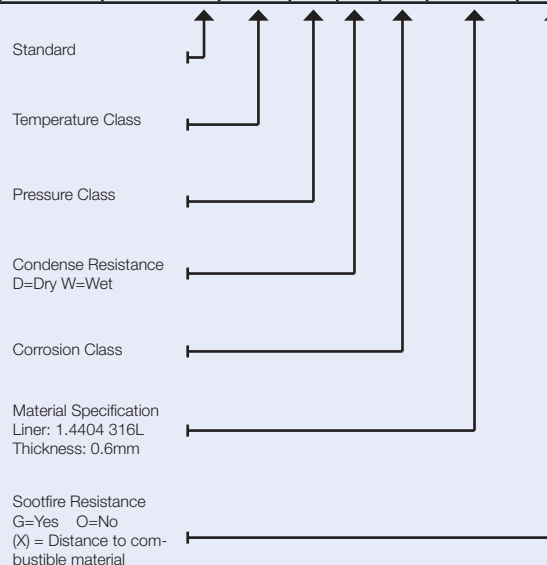

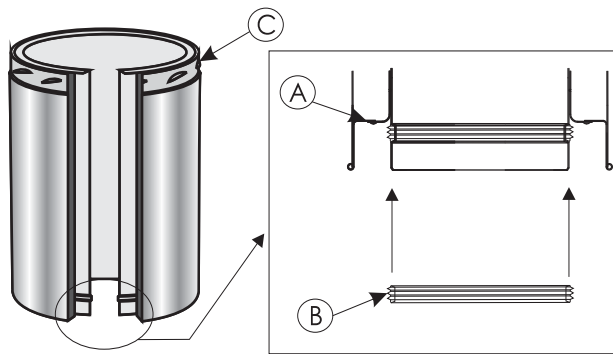

A - Coupler Separator

The coupler separator is a 1mm dimple which is designed to allow a controlled amount of air to pass across the coupler interface. This limits thermal bridging and heat transfer across the joint as well as reducing the potential for capillary moisture movement.

B - Elastomer Seal

The NOVA product offers a retrofit EPDM elastomer seal that can be fitted around the inner groove as shown above. The seal facilitates positive pressure and condensate resistance up to 200Pa at a maximum flue gas temperature of 120°C, offering a P1 rating to BS EN 1856-1.

For higher pressure capability, please refer to SFL Technical Department.

C - Quick Lock Jointing System

The NOVA joint incorporates a multi-barbed coupler system to allow easy and rapid installation of the product. When used with the NOVA support components the joint will support up to 2.5 metres free standing above the last support, see installation commencing from Page 8 for further details.

D - Locking Band

The Locking Band is used to complete the joint and incorporates a heavy duty adjustable toggle latch for improved speed of installation and strength.

Joint Assembly:

The joint is made by fitting the female end over the male end and engaging the joint system by rotating the component clockwise. A Locking Band is then fitted to finish the joint, as detailed in Fig. 1.

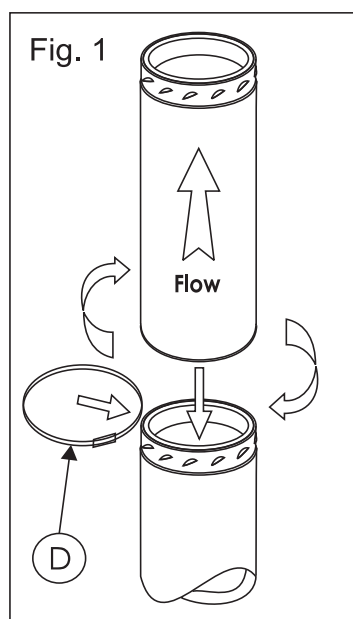

Regulation Guidance

In all instances, the chimney installation must comply to the relevant National Standards and Regulations for the particular country where being installed. For gas fired appliances in the UK with input between 70kW and 1.8MW (net), the installation should conform to BS 6644:2005 or BS 5440: Part 1: 2008 below this rating. For other European Countries, reference should be made to EN 15287: Part 1: 2007: Design, Installation & Commissioning of Chimneys. The National Annex NA of EN 15287-1 should detail the national regulatory requirements for that particular country.

Chimney Height

For gas fired applications under the requirements for BS 6644: 2005, the flue should terminate at least 1.0 metre above the roof surface. Where the terminal is located within a distance of 2.5 metres from a nearby structure, then the chimney must terminate a minimum of 1.0 metres above the structure. Consideration must also be given to the requirements of the Clean Air Act or equivalent, depending on county of installation. For UK requirements, appliances where the combined input is greater than 366.4kW, the chimney must be designed to meet the requirements of the Clean Air Act. In most cases the chimney height can be calculated in accordance with Clean Air Act Memorandum, which takes into account the fuel type, rated input, building heights and general topography of the surrounding area.

Distance To Combustible Material

Nova Commercial must be installed to offer a minimum clearance of 50mm to any combustible material. Where the product is being used with condensing and naturally aspirated appliances, a clearance of 25mm would be considered acceptable. All Nova support components are designed to offer 50mm clearance between the structure and outer case of the product.

Provision For Condensate Removal

Where Nova is being used for condensing appliances or wet systems, it is important that the chimney is designed in such a way as to ensure adequate drainage of condensation from the system. As a rule of thumb, a condensing appliance will produce 1 to 1.5 litres of condensate per hour per 10kW of heat input. To facilitate correct remove of condensation from the system, suitable drainage components must be used. To further facilitate correct drainage, the system must be installed so that no run is less than 5° from the horizontal. The Nova system offers a range of components to achieve this including 95° Tee, 85° and 40° elbows. Failure to achieve a minimum 5° rise could result in premature failure of both the seals and liner. It is suggested that drainage points are included at the base of any vertical riser and at the lowest point of any inclined run. When used on wet system, seals must be fitted to each joint and adequately lubricated prior to making the joint. It is recommended that SFL Seal Lubricant (Part No. 4007500) is used for lubricating all joints prior to installation.

Lengths & Fittings

Nova Commercial offers a continuation of the standard Nova products, offering a complete range of pre-fabricated component, covering 400mm, 450mm, 500mm, 550mm and 600mm internal diameter. All SFL components are designed to meet today's demands and offer a flexible, installer friendly product. Standard components include fixed lengths, adjustable lengths, angled elbows, angled tees, vertical and lateral support, appliance adaptors, inspection components and terminals.

Support Components

Nova Commercial offers a full range of support components, offering both vertical and lateral loading capability, while allowing total flexibility and safety when installing the product.

Vertical Supports

Adjustable Wall Support Brackets, Support Plates and Support Lengths are available to facilitate the vertical loading of the chimney. Support components are available in either stainless steel or galvanised steel if used for internal applications. Please refer to Page 7 for further information and Page 11 for structural loading capabilities.

Lateral Supports

Wall Bands are available for the lateral support of the installation. These are available in both galvanised steel and stainless steel for external applications. All Wall Bands offer a 50mm clearance from the outer case of the chimney to the structure. For further information please refer to page 7 & 9

Please note, that whilst the product is manufactured from stainless steel, certain environments can lead to premature corrosion. Consideration should be given to the following conditions:-

Coastal Location: Where Nova Commercial is being installed in a coastal location, we would recommend that a suitable coating is applied to the outer case. Alternatively, SFL can manufacture the products with a 1.4404 (316L) grade stainless steel outer case. For further information, please call SFL Technical Department.

Chemical Contamination: This occurs when chemicals within the environment are mixed with the air for the combustion equipment and breaks down in the combustion process, creating various aggressive compounds. Typical examples where there is a potential for combustion air contamination include de-greasing plant and dry-cleaning systems. Where there is a possibility that the environment could be contaminated, please consult SFL Technical Department for advice.

Commercial Installations

Bespoke and Special Components

SFL appreciates that there are times when special bespoke components are required, due to possible site constraints or where the design cannot incorporate standard components. At SFL we have over 40 years experience in the manufacture of special bespoke chimney components, ranging from complete manifolds, reducing tees, special angled elbows, probe lengths, material specification, support components and many more. For more details, please forward a drawing of your requirements to SFL Technical Department, who will analyse the feasibility of your request.

Flue Sizing & Design

Using the latest CAD software, SFL can model both the flow characteristics and thermal dynamics of your design, to achieve the most economic and efficient chimney design. All designs are calculated and modelled in accordance with EN 13384 Parts 1 & 2. SFL can also advise on all aspects of chimney design, Clean Air Act requirements and calculations, current regulations and national standards.

Typical Commercial Installation

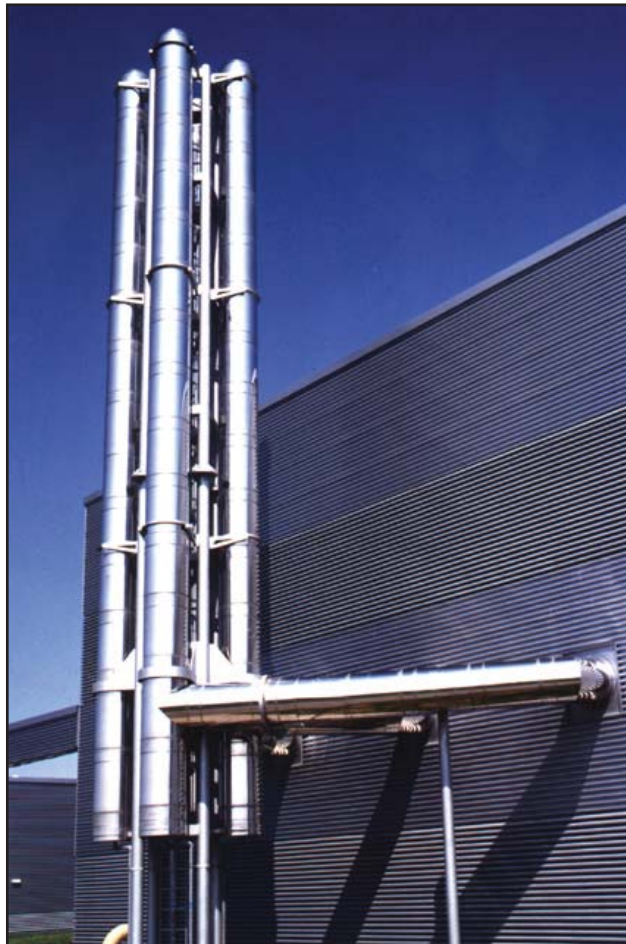

Lengths

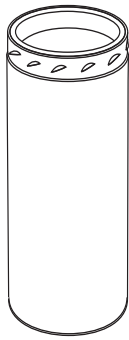

Straight Lengths

Straight lengths are available in nominal installed lengths of 1000mm, 500mm and 250mm.

Size	Code Numbers		
	1000mm	500mm	250mm
400mm	4575016N	4575116N	4571916N
450mm	4575018N	4575118N	4571918N
500mm	4575020N	4575118N	4571920N
550mm	4575022N	4575120N	4571922N
600mm	4575024N	4575124N	4571924N

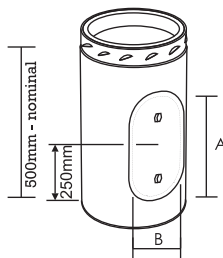

Inspection Length

Used to provide access for cleaning and inspection. For pressure and wet applications both the inner and outer door seals **MUST** be fitted to the product.

Size	Dimensions		Code
	A	B	
400mm	100	200	4576316N
450mm	100	200	4576318N
500mm	100	200	4576320N
550mm	100	200	4576322N
600mm	100	200	4576324N

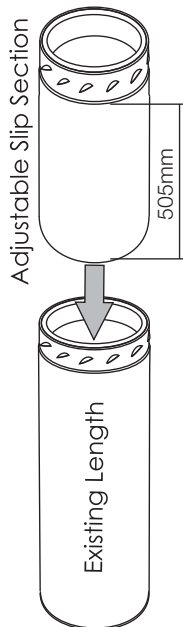

Adjustable Length

The Adjustable Length offers a degree of flexibility when standard dimensions are not suitable. The Adjustable Length is 505mm long and is designed to slide over an existing standard length and **MUST** be engaged by at least half the diameter of the product being installed. Adjustable Lengths are supplied with separate insulating material for insertion into the annulus once the installed length has been determined.

For positive pressure and wet applications a seal must be fitted to the liner of the product in accordance with the installation instructions.

Size	Code
400mm	4576616N
450mm	4576618N
500mm	4576620N
550mm	4576622N
600mm	4576624N

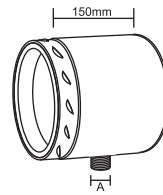

Horizontal Duct Drain

Used in horizontal or inclined positions to trap condensation and permit drainage from the system. It is fitted with a standard stainless steel BSP threaded connection.

Size	A	Code
400mm	2" BSP	4576816N
450mm	2" BSP	4576818N
500mm	2" BSP	4576820N
550mm	2" BSP	4576822N
600mm	2" BSP	4576824N



Locking Band

A Locking Band must be used to finish all joints. A Locking Band is provided with each component that has a female end.

Size	Code
400mm	4578616
450mm	4578618
500mm	4578620
550mm	4578622
600mm	4578624

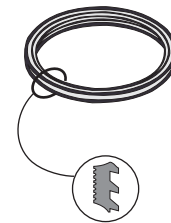

EPDM Joint Sealing Ring

This optional component is available for all diameters and is located in the joint groove as detailed in Fig 8 page 12. This component provides a moisture and gas resistant seal to a pressure of 200Pa as tested to P1 under BS EN 1856-1. The seal would normally be used on applications where there is a likelihood that condensation of the flue gases could result or where the chimney is operating under positive pressure applications where the flue gas temperature will not exceed 120°C (T120).

Important:

The SFL Seal Lubricant below, should be applied around the surface of the seal prior to making the joint. It is also recommended that the seal is bonded to the fixing groove prior to installation with a suitable adhesive, allowing sufficient time to cure. Both mating ends should be clean and free of dirt before making the joint.

Size	Code
400mm	4006540
450mm	4006545
500mm	4006550
550mm	4006555
600mm	4006560

Under no circumstances should the elastomer seal be used on any other fuel except gas.



Seal Lubricant (W / P1)

This must be applied around the circumference of the fitted seal to provide a lubricated interface between the seal and the liner when the product is used for positive pressure and wet systems.

Seal Lubricant	4007500
----------------	---------

Adaptors

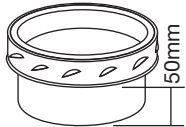

Appliance Adaptor

This facilitates connection of the Nova chimney system to the appliance. This adaptor is also used for the connection of the Draught Stabiliser to the branch of a 90° Tee.

Size	Code
400mm	4579416N
450mm	4579418N
500mm	4579420N
550mm	4579422N
600mm	4579424N

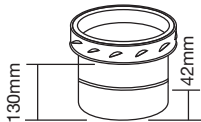

Appliance / Supra Adaptor

Used to either connect the chimney system to the appliance or to the SFL Supra chimney system. Bespoke adaptors can be made to order, please refer to SFL.

Size	Code
400mm	4579616N
450mm	4579618N
500mm	4579620N
550mm	4579622N
600mm	4579624N

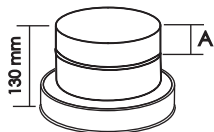

NOVA to SUPRA Adaptor

Designed to enable connection from the NOVA to SUPRA chimney system.

Size	A	Code
400mm	42	4579716N
450mm	-	-
500mm	42	4579720N
550mm	-	-
600mm	42	4579724N

Elbows, Tees & Fittings



15° Elbow

Provides a 15° change of direction from the vertical. See technical data on page 13 for dimensions.

Size	Code
400mm	4575416N
450mm	4575418N
500mm	4575420N
550mm	4575422N
600mm	4575424N



30° Elbow

Provides a 30° change of direction from the vertical. See technical data on page 12 for dimensions.

Size	Code
400mm	4575516N
450mm	4575518N
500mm	4575520N
550mm	4575522N
600mm	4575524N

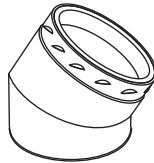

40° Elbow

Provides a 40° change of direction from the vertical. See technical data on page 12 for dimensions.

Size	Code
400mm	4575616N
450mm	4575618N
500mm	4575620N
550mm	4575622N
600mm	4575624N

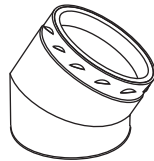

45° Elbow

Provides a 45° change of direction from the vertical. See technical data on page 12 for dimensions.

Size	Code
400mm	4575716N
450mm	4575718N
500mm	4575720N
550mm	4575722N
600mm	4575724N

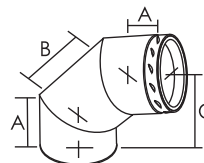

85° Elbow

Provides a 85° change of direction from the vertical. Used in condensing applications where a 5° incline to the horizontal is required for condensate drainage.

Dimension lines relate to centre line of component.

Size	Dimensions			Code
	A	B	C	
400mm	154	247	350	4575816N
450mm	164	268	376	4575818N
500mm	174	289	403	4575820N
550mm	185	310	430	4575822N
600mm	195	330	456	4575824N

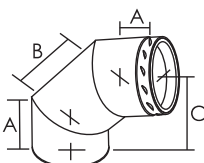

90° Elbow

Provides a 90° change of direction from the vertical.

Dimension lines relate to centre line of component.

Size	Dimensions			Code
	A	B	C	
400mm	154	247	329	4575916N
450mm	164	268	354	4575918N
500mm	174	289	379	4575920N
550mm	185	310	404	4575922N
600mm	195	330	429	4575924N

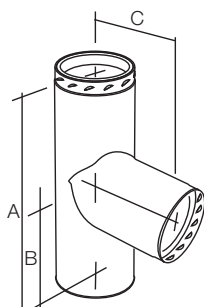

90° Equal Tee

Used at the base of a vertical chimney, or for horizontal header configurations.

Size	Dimensions			Code
	A	B	C	
400mm	700	350	350	4577616N
450mm	750	375	375	4577618N
500mm	800	400	400	4577620N
550mm	1000	500	500	4577622N
600mm	1000	500	500	4577624N

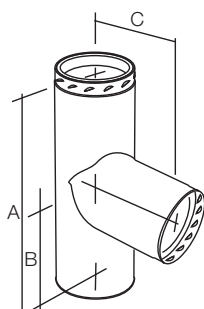

95° Equal Tee

Used at the base of a vertical chimney, or for horizontal header configurations. Allows for a 5° incline on wet systems to facilitate condensate drainage.

Size	Dimensions			Code
	A	B	C	
400mm	700	350	350	4576416N
450mm	750	375	375	4576418N
500mm	800	400	400	4576420N
550mm	1000	500	500	4576422N
600mm	1000	500	500	4577624N

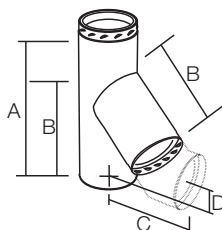

135° Equal Tee

Used at the base of a vertical chimney, or to allow a smooth transition from the horizontal to the vertical plain when used with a 45° elbow.

Size	Dimensions		Code
	A	B	
400mm	1000	675	4576516N
450mm	1000	750	4576518N
500mm	1000	810	4576520N
550mm	1000	785	4576522N
600mm	1050	860	4576524N

Size	Dimensions 135° Tee c/w Elbow on Branch			
	With 40° Elbow		With 45° Elbow	
	C	D	C	D
400mm	749	75	739	89
450mm	810	89	810	104
500mm	869	89	870	114
550mm	870	83	871	100
600mm	952	90	941	114

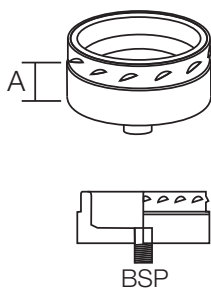

Condensate Collector

Used at the bottom of a vertical chimney to facilitate drainage of condensation from the system. All sizes are fitted with a 2" BSP stainless steel drain boss.

Size	Dimensions		Code
	A		
400mm	50		4576916N
450mm	50		4576918N
500mm	50		4576920N
550mm	50		4576922N
600mm	50		4576924N



Locking Plug

Used to close off the branch or base of a Tee.

Size	Dimensions		Code
	A		
400mm	50		4579116N
450mm	50		4579118N
500mm	50		4579120N
550mm	50		4579122N
600mm	50		4579124N

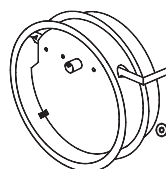

Draught Regulator

Dual action draught regulator suitable for gas and oil fired appliances. Designed to be used with SFL chimney systems where excessive draught is likely to create combustion problems. Where used with the Nova chimney system, the regulator should be applied with the 45794XX Appliance Adaptor, where XX relates to the diameter and located into the branch of a 90° Tee.

Size	Dimensions		Code
	A		
400mm			3192016
450mm			3192018
500mm			3192020
550mm			3192022
600mm			3192024

Floor Penetration Components

The following components MUST be used on gas or oil fired appliances where the flue gas temperatures do not exceed 250°C.

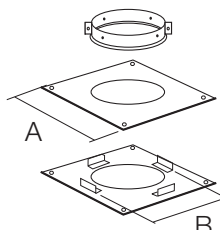

Ceiling Support

Provides a 50mm air gap clearance to a penetrated floor or ceiling and is only used where the Nova product penetrates a non-combustible floor, and/or serves a gas or oil fired appliance where the flue gas temperatures do not exceed 250°C.

Size	Dimensions		Code
	A	B	
400mm	605	555	4502716
450mm	655	605	4502718
500mm	711	661	4502720
550mm	762	712	4502722
600mm	813	763	4502724

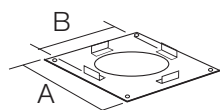

Firestop Spacer

Used to provide location, fire and dust stopping where NOVA is used through non-combustible floors, and / or serves a gas or oil fired appliance where the flue gas temperatures do not exceed 250°C. This item is non-loadbearing.

Size	Dimensions		Code
	A	B	
400mm	605	555	4508716
450mm	655	605	4508718
500mm	711	661	4508720
550mm	762	712	4508722
600mm	813	763	4508724

Support Components



Support Length / Guy Bracket

A 117mm installed length which incorporates a support plate located 33mm from the bottom edge and features slotted holes for rotational adjustment. For use with the Universal Support Plate or as a Support Length for bespoke bracketry. This component also doubles as a strut / guy attachment length offering anchoring points to which guys, or preferably rigid stays can be secured using M8 nuts and bolts. Manufactured from stainless steel.

Size	Code
400mm	4578816N
450mm	4578818N
500mm	4578820N
550mm	4578822N
600mm	4578824N

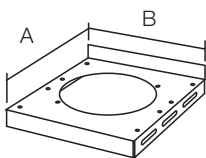

Wall Support Assembly

Used to take the vertical load of the chimney when supported from a wall. The Support is fully adjustable allowing varying clearances from the wall (50mm as standard). Requires M10 wall fixings.

Size	Dimensions		
	A	B	C
400mm	580	551	518
450mm	631	602	569
500mm	680	651	618
550mm	731	702	669
600mm	780	751	718

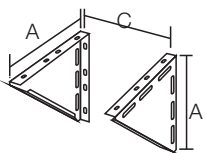

Wall Support Bracket

Supplied complete with a Support Length to allow for base or intermediate support of the chimney.

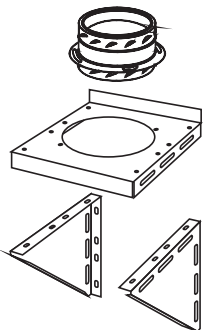

Size	Code	
	Stainless	Galvanised
400mm	4572316	4572216
450mm	4572318	4572218
500mm	4572320	4572220
550mm	4572322	4572222
600mm	4572324	4572224

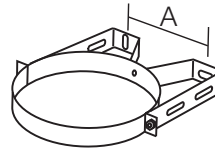

Wall Bands

Wall Bands provide lateral support for the chimney and must be used at intervals not exceeding 4.0 metres above any load bearing support. For external applications it is recommended that the stainless steel version is used.

Size	A (mm)	Code	
		Stainless	Galvanised
400mm	421	3115455	3116455
450mm	472	3115505	3116505
500mm	522	3115555	3116555
550mm	572	3115605	3116605
600mm	622	3115655	3116655

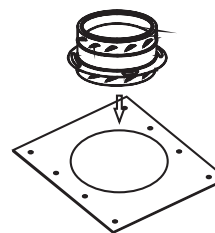

Universal Intermediate Support Plate

A Support Plate designed for use with bespoke bracketry such as Uni-Strut / Neissing or site fabricated. For use with a Support Length (Must be ordered separately).

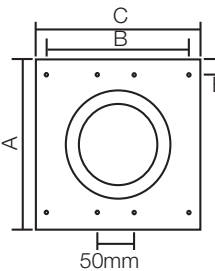

Size	Dimensions			Code Number	
	A	B	C	Stainless	Galvanised
400mm	580	469	551	311916454	311016454
450mm	631	540	602	311918504	311020554
500mm	680	589	651	311920554	311022604
550mm	731	640	702	311922604	311022604
600mm	780	689	751	311924654	311024654

Terminals, Flashings & Trims



Top Stub

The terminal offers the least resistance and is ideal for solid fuel and oil fired appliances, providing there is drainage at the base of the chimney.

Size	A (mm)	Code
400mm	150	4570816
450mm	150	4570818
500mm	150	4570820
550mm	150	4570822
600mm	150	4570824

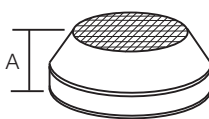

Top Stub c/w Mesh

The terminal offers the least resistance to flue gases and is ideal high efficiency appliances where acceptable. Not suitable for solid fuel.

Size	A (mm)	Code
400mm	150	4570716
450mm	150	4570718
500mm	150	4570720
550mm	150	4570722
600mm	150	4570724

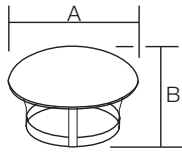

Rain Cap

The Rain Cap offers a degree of protection from rain and is suitable for solid fuel and oil fired appliances. The Rain Cap can also be used on gas fired appliance where the chimney diameter is greater than 200ID.

Size	Dimensions		Code
	A	B	
400mm	716	454	4577316
450mm	716	467	4577318
500mm	716	482	4577320
550mm	716	504	4577322
600mm	1000	436	4577324

Aluminium Flashings

The SFL Aluminum Flashing range offers a competitive alternative to the traditional lead flashing, while still maintaining a traditional design and malleable material. All Aluminum Flashings require a Storm Collar.

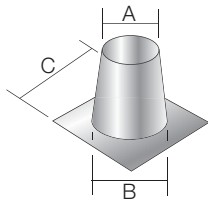

Flat Flashing

For flat or nearly flat roofs.

Size	Dimensions (mm)			Code
	A	B	C	
400mm	460	550	862	70000015
450mm	510	600	914	70000016
500mm	560	650	965	70000017
550mm	610	700	1015	70000018
600mm	660	750	1066	70000019

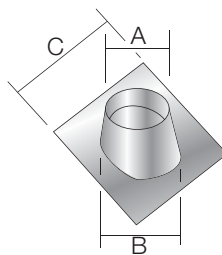

5° - 30° Flashing

For low pitched roofs

Size	Dimensions (mm)			Code
	A	B	C	
400mm	460	652	952	70053015
450mm	510	710	1010	70053016
500mm	560	766	1066	70053017
550mm	610	824	1124	70053018
600mm	660	880	1180	70053019

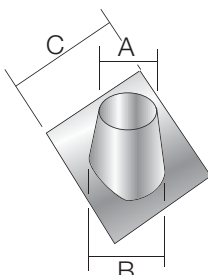

32° - 45° Flashing

For high pitched roofs

Size	Dimensions (mm)			Code
	A	B	C	
400mm	460	750	1041	70324515
450mm	510	812	1124	70324516
500mm	560	892	1220	70324517
550mm	610	963	1300	70324518
600mm	660	1034	1300	70324519

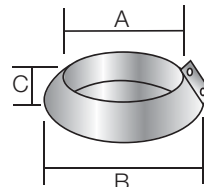

Storm Collar

Used to weather seal the top of the Flashing. Supplied with a tube of silicon sealant.

Size	Dimensions (mm)			Code
	A	B	C	
400mm	452	625	150	70123415
450mm	502	675	150	70123416
500mm	552	725	150	70123417
550mm	602	775	150	70123418
600mm	652	825	150	70123419

Installation Instructions

Detailed installation instructions are provided with Adaptors and all Terminals, and are also available separately on request, however detailed below are key installation requirements for the NOVA chimney system together with regulatory requirements for the UK. For countries outside of the UK, please refer to the countries own regulations and national standards.

General

1 The installation of the NOVA product must be in accordance with local Building Regulations and associated National Standards and Codes of Practice. For additional guidance, reference can be made to BS EN 15287: Part 1- Design, Installation & Commissioning of Chimneys. The National Annex (NA) of EN 15287: Part 1 will detail the national requirements particular to the country.

Every chimney section and fitting shall be used as manufactured for assembly on site without any alteration or cutting. Components are joined with a multi-barbed twist-lock coupler, and secured with a Locking Band. All components must be installed with the male coupler facing up as detailed in Fig.1.

Nova is suitable for both internal and external applications. Where used on high efficiency condensing appliances, a range of components are available to permit deliberate drainage of condensate, either back to the condensate removal component within the chimney system, or through the heating appliance. No part of the chimney system should be constructed to form an angle greater than 45° from the vertical. Although components are included that will permit horizontal application, they should only be used for connection to the appliance. Where the system is being used for a condensing application, sections must run at an angle of 5° from the horizontal, using tees, elbows and fittings designed for that purpose. Failure to provide adequate drainage could lead to premature failure of the product and seal.

Offsets can be constructed using elbows, lengths and adjustable components available within the system. For full details regarding offset dimensions and heights for various elbow/length combinations, refer to Page 12.

The diameter of the chimney should be as recommended by the appliance manufacturer. Where the chimney route is complex, the diameter of the chimney should be calculated in accordance with:

- BS EN 13384-1: Chimneys servicing a single appliance**
- BS EN 13384-2: Chimneys serving multiple appliances**

If required SFL can help in the sizing and design of all chimney systems to the above standards using the latest flow modelling software to ensure the most economic and efficient chimney size for the given application and design.

Chimney Heights

2 The termination height of a chimney is determined by national standards and regulations. The following publications may be referred to for guidance with respect to chimney termination heights:

Building Regulations

BS 5440-1: Gas appliances with a rated input not exceeding 70 kW net.

BS 6644: Specification and installation of gas-fired hot water boilers of rated net inputs between 70 kW and 1.8 MW.

BS 5410-1: Code of practice for oil fire appliances with a rated output not exceeding 45 kW.

BS EN 15287-1: 2007 Design, installation and commissioning of chimneys for non-roomsealed heating appliances.

Clean Air Act 1993

Third Edition of the Chimney Heights Memorandum.

Where the total rated input of a single appliance or the combination of several appliances is greater than 366.4 kW, the chimney height must comply with the requirements of the Clean Air Act 1993. It is a requirement that the height of any chimney serving an appliance/s at or above this figure are approved by the Local Authority prior to any installation taking place. For initial assessment of the chimney height, reference can be made to the Third Edition of the Chimney Heights Memorandum which offers a relatively simplified method for calculating the approximate chimney heights for applications between 150 kW and 150 MW. The Third Edition of the Chimney Heights Memorandum is available from the Office of Public Sector Information (www.opsi.gov.uk).

The SFL Technical Department can assist with basic chimney height calculations in accordance with the Chimney Height Memorandum for oil and gas fired applications.

When considering chimney heights for Bio Fuel applications, consideration should be given to the possibilities of particulates entering into the flue gases. For this reason advice should be sought from the Local Authority or Environmental Department when determining the required chimney height, as a more detailed dispersal model may be required.

Adjustable Length

3 The Adjustable Length is designed to be used where standard lengths cannot achieve the required distance. A typical example is where a specific distance is required to offset the chimney between two elbows. The Adjustable Length is designed to slide over an existing standard length to offer a degree of adjustability. Please note that the Adjustable Length **MUST** engage the existing length by a minimum of half of the internal diameter of the chimney.

To commence installation, firstly establish the distance to be taken up by the adjustable length and ensure that the liner of the component will engage into the proceeding standard length by at least half the internal diameter. Using the supplied insulation material, fill the Adjustable Length to a depth to coincide with the distance to be taken up by the component. Before installing the Adjustable Length, should the application demand pressure and condensate resistance, ensure that the seal is fitted around the groove on the tail of the inner liner and ensure that it is well lubricated, see Fig 2. Taking care not to damage the seal, carefully slide the Adjustable Length over the proceeding length until the correct distance is made. Once in position, drill and secure the outer case to the proceeding length with the self tapping screws provided.

Fig. 2 Adjustable Length Assembly

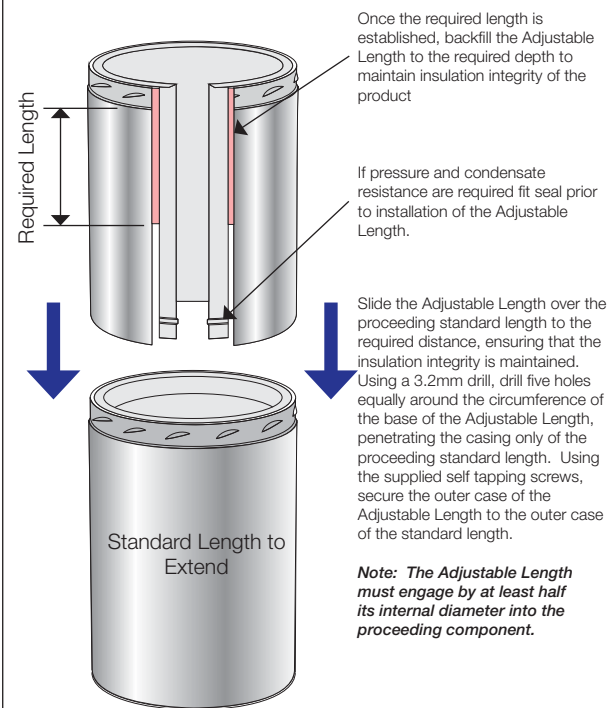

Wall Bands

4 Wall Bands provide lateral support for the product and must be installed every 4.0 metres where the product rises vertically. A Wall Band must also be used to brace the top and bottom of any angled offset. Where used externally, the stainless steel version **MUST** be used. Wall Bands can also be used to suspend horizontal runs where required.

The Wall Band consists of two components, the Back Fixing Bracket complete with Back Ring and the Front Securing Ring. For installation, unscrew the fixing bolts and remove the Front Securing Ring. The Back Ring can be rotated 90° to facilitate access to the fixing slots in the Rear Fixing Bracket. Ensuring the Rear Fixing Bracket is level, mark the hole positions and drill fixing holes. The fixings should be of adequate size to securely attach the Wall Band to the wall. Position Rear Fixing Bracket against wall and secure to wall with suitable fixings. Rotate the Back Ring back to its original position so that the fixing holes of the Back Ring align with the Nut Inserts on the Rear Fixing Bracket. Position the chimney against the Back Ring and secure the Front Ring with the M8 Bolts provided. See Fig. 3.

Fig. 3 Wall Band Assembly

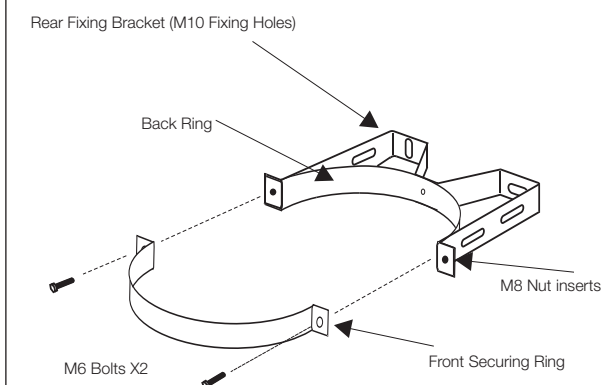

Wall Support Assembly

5 The Wall Support Assembly is used to support the vertical loading of the chimney system.

The kit consists of a Support Plate, two Wall Support Side Brackets and a Support Length. As the Support Plate can be moved on the Side Brackets to adjust the wall clearance, the actual loading capability will vary depending on the chimney diameter. The Support Plate may also be used on its own or with other suitable support arrangements. In either case it is always used with a Support Length, bolted to the top surface of the Support Plate with fittings supplied, see Fig. 4 and Fig. 6. Wall Supports must be secured to the structure with fixings adequate for the purpose. In all cases the maximum loading data must be observed.

Special consideration must be given to where a fitting such as a 90° or 135° Tee is being vertically loaded on the top side of the Support Plate. Where ever possible the chimney inlet fitting should be positioned on the underside of the Wall Support Assembly to minimise loading on the fitting, see table on Page 13 for component loading data.

Fig. 4 Wall Support Assembly

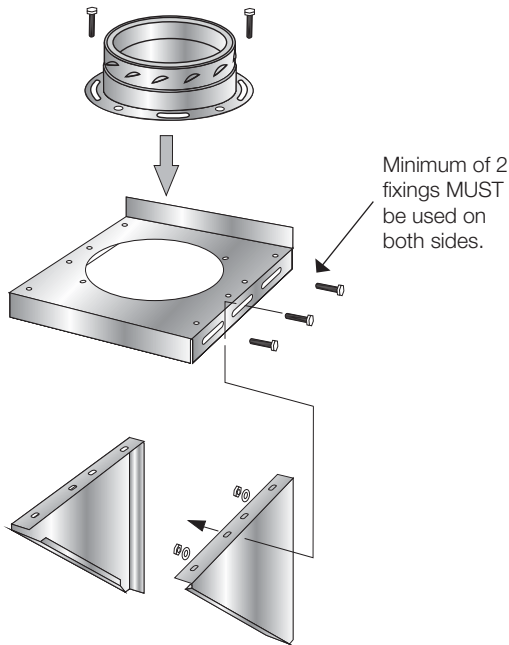

Fig. 5 Wall Support Assembly Clearance

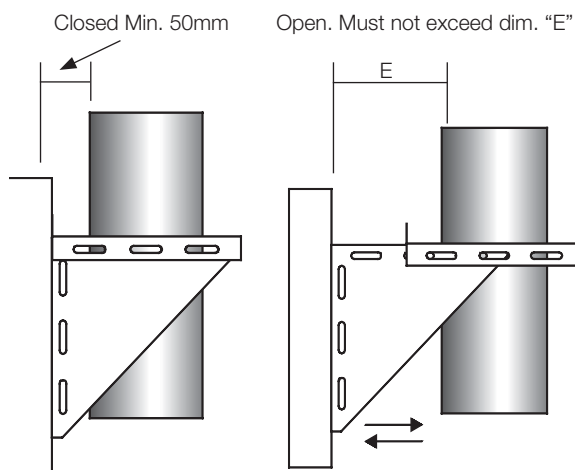
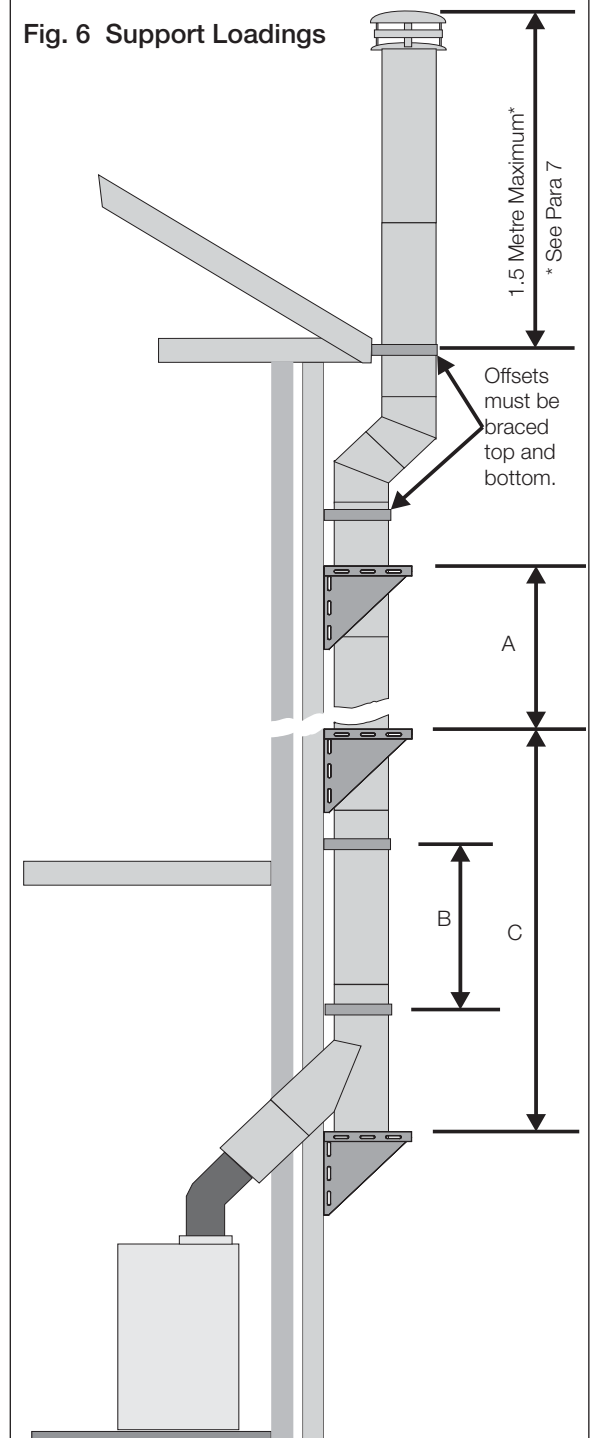

Fig. 6 Support Loadings



Maximum Wall Support Clearances for Fig. 5.

Size	E (mm)
400mm	314
450mm	340
500mm	360
550mm	362
600mm	414

Maximum Loading

6 When installing the product, careful consideration needs to be given to the correct support of the product. Various components are available to undertake the vertical and lateral loading of the product to ensure safe installation. With respect to Fig. 6, in all cases the maximum loading data detailed within the table below **MUST** be complied with.

Where the constraints of site and installation require bespoke site manufactured bracketry, the Universal Support Plate and Support Length should be used with the fabricated bracketry. In all cases it is strongly suggested that expert advice is sought from a Structural Engineer.

Fittings that are used as chimney inlets such as 90°, 95° & 135° Tees should be loaded by no more than 2 metres of product before a Wall Support Assembly is used to take the vertical weight of the preceding chimney. Please refer to Fig 6 dimension C for further clarification.

Maximum Loadings from Fig. 6

Size	A (m)		B (m)	C* (m)
	Closed	Open		
400mm	20	15	4	2
450mm	20	12	4	2
500mm	18	10	4	2
550mm	15	10	4	2
600mm	15	10	4	2

* Chimney inlet components must not be loaded vertically by more than 2 metres prior to fitting a Wall Support Assembly.

Maximum Freestanding Termination Heights

7 Due to the multi barbed coupled jointing system employed by the product, Nova has considerable strength at its joints. Providing the installation requirements of Fig. 7 are complied with, the Nova product can support a free standing height of 2.5 metres. The maximum unsupported height otherwise is 1.5 metres, for example where there is a braced offset directly below the termination height or the installation does not meet the requirements of Fig. 7.

Installing Elastomer Seals for Condensate and Pressure Resistance

8 When Nova is being installed for applications that require condensate and pressure resistance, elastomer seals must be fitted to the product on every joint. SFL use high quality EPDM elastomer seals offering superior corrosion resistance and strength. Under **NO** circumstances should the seals be used with any other fuel other than gas. The installation procedure for the seals is as follows and as shown in Fig. 8:

1. Using a cloth, ensure that both the seal location groove and the inner throat of the male end are clean and free of dirt.
2. Position the seal over the inner liner protruding from the female end and ensure that the seal locates firmly within the seal location groove. The seal must be installed so that the vanes are on the outside of the pipe, see Fig. 8.
3. Apply a generous amount of SFL Seal Lubricant around both the face of the seal and around the inner throat of the male end.
4. Carefully position the female end over the male end of the preceding component so that the inner liner tail is engaging into the throat of the male end.
5. Slowly push the joint together so that the seal engages fully into the male end, turn the component clockwise to lock the barbs and apply the Locking Band to finish the joint.

Note: Some manipulation may be required to ensure that the locking barbs are not engaging while trying to push the joint together, simply turn the component clockwise while pushing the ends together.

Fig.7

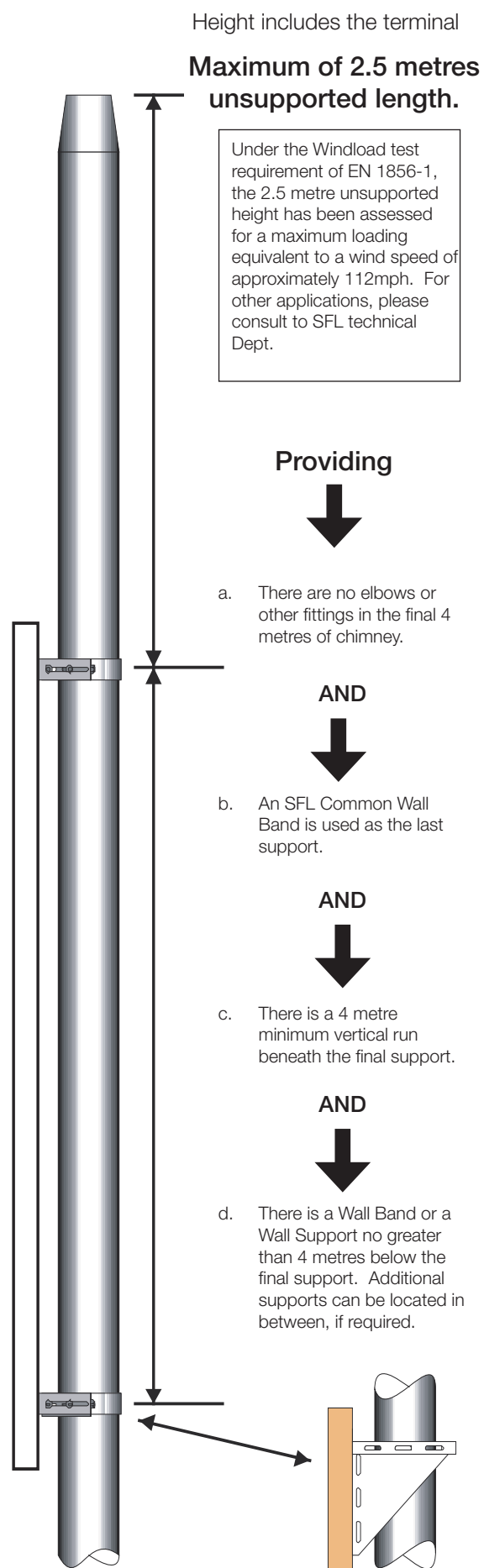

Fig. 8 Seal Installation

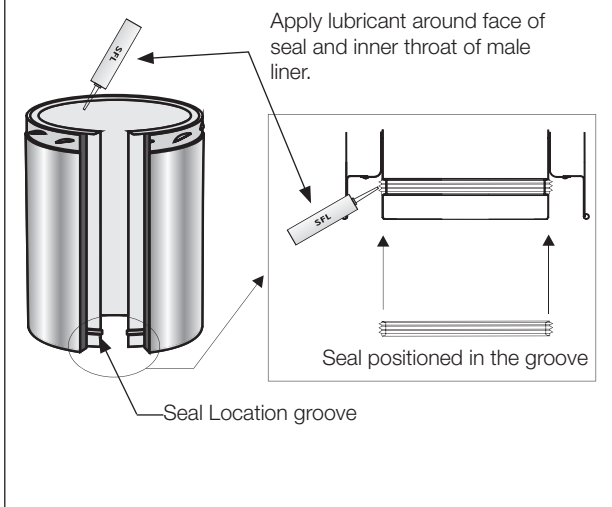
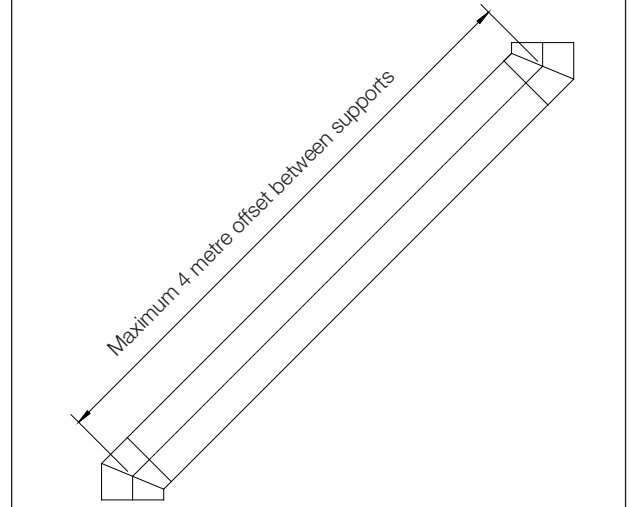

Fig. 9 Maximum Offset Distance



Elbow Offset Dimensions

The dimensions in the charts below relates to both single angled offsets and angled offsets utilising standard lengths. The maximum unsupported length between two supported elbows is 4 metres, see Fig. 9.

Single Offset Dimensions as Fig. 10

Size	15°			30°			40°			45°		
	A	B	C	A	B	C	A	B	C	A	B	C
400mm	154	606	80	154	575	154	154	544	198	154	526	217
450mm	164	645	85	164	612	164	164	579	211	164	560	232
500mm	174	684	90	174	649	174	174	615	224	174	594	246
550mm	185	727	96	185	690	185	185	653	238	185	632	262
600mm	195	767	101	195	728	195	195	689	251	195	666	276

Offset Dimensions With Standard Lengths as Fig. 11

Size	120mm Length							
	15°		30°		40°		45°	
	B	C	B	C	B	C	B	C
400mm	722	111	679	214	638	275	611	303
450mm	761	116	716	224	671	288	645	317
500mm	800	121	753	234	707	301	679	331
550mm	843	127	794	245	745	315	717	347
600mm	883	132	832	255	781	328	751	361

Size	250mm Length							
	15°		30°		40°		45°	
	B	C	B	C	B	C	B	C
400mm	847	144	791	279	736	359	703	395
450mm	886	150	828	289	771	372	732	409
500mm	926	155	866	299	806	384	771	423
550mm	969	160	907	310	845	399	808	438
600mm	1008	166	944	320	880	411	843	453

Size	500mm Length							
	15°		30°		40°		45°	
	B	C	B	C	B	C	B	C
400mm	1089	209	1008	404	927	519	880	572
450mm	1128	214	1045	414	962	532	914	586
500mm	1167	219	1082	424	998	545	948	600
550mm	1210	225	1123	435	1036	559	986	616
600mm	1250	230	1161	445	1072	572	1020	630

Size	1000mm Length							
	15°		30°		40°		45°	
	B	C	B	C	B	C	B	C
400mm	1572	339	1441	654	1310	841	1233	925
450mm	1611	344	1478	664	1345	854	1267	939
500mm	1650	349	1515	674	1381	867	1301	953
550mm	1693	350	1556	685	1419	881	1339	969
600mm	1733	355	1594	695	1455	894	1373	983

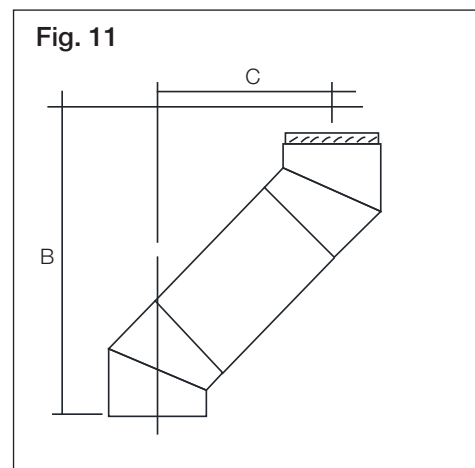
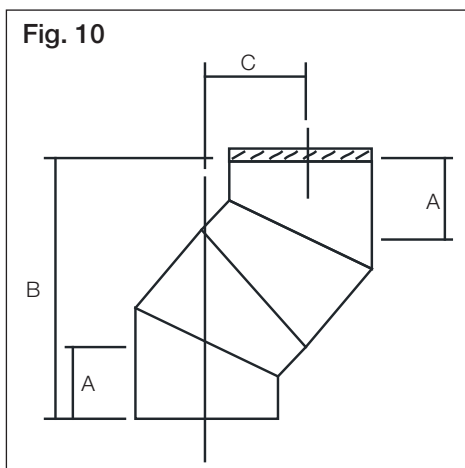

Typical Installation

Note: For condensing and pressure applications EPDM Elastomer Seals MUST be used on each joint.

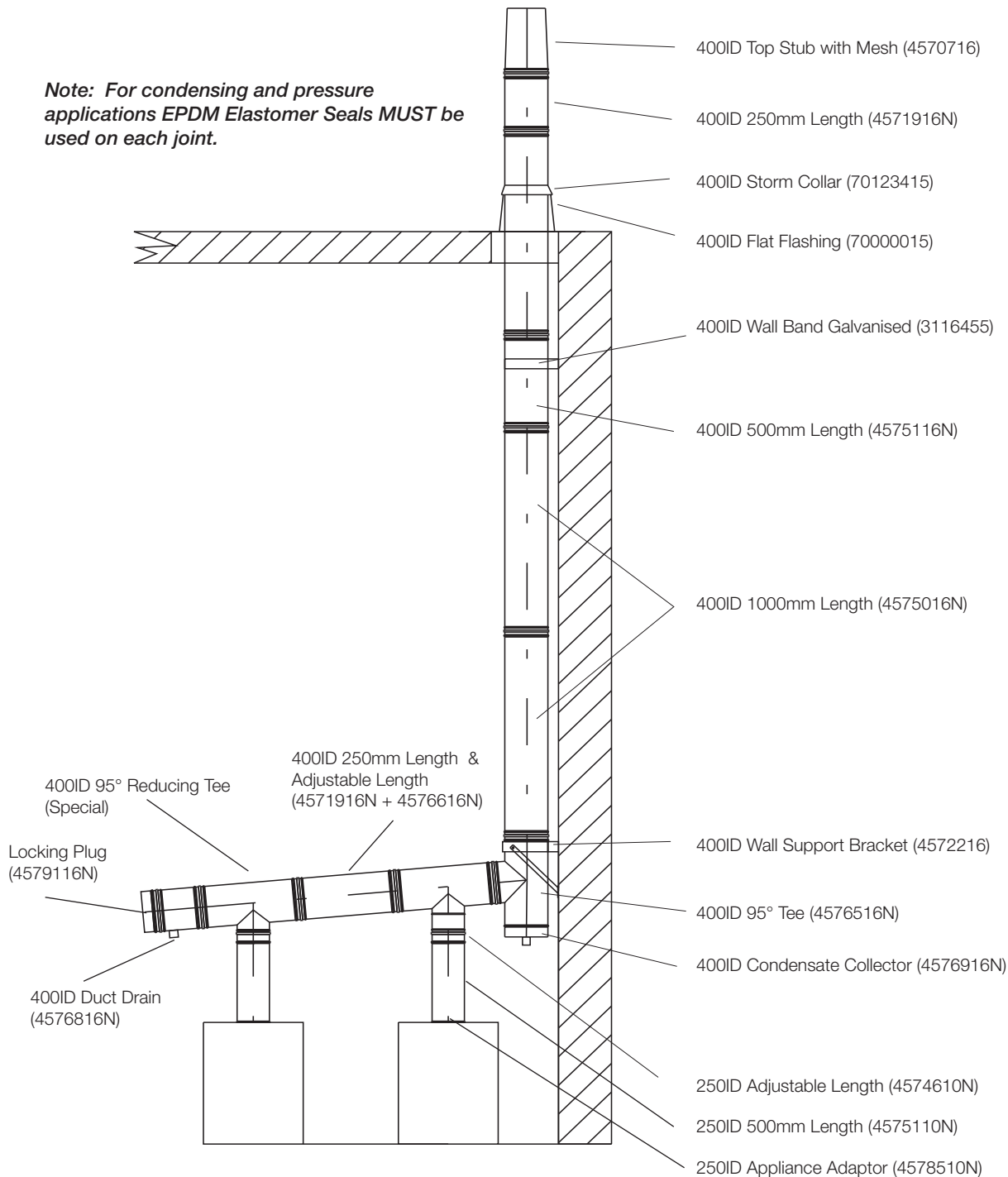

The typical installation detailed above shows the product being used to vent two commercial condensing appliances using a common manifold arrangement. This installation demonstrates the drainage requirements and the available components to ensure the correct removal of condensation from the system. It can be seen that the manifold inclines at an angle of 5° to the vertical and this is achieved using the appropriate 95° tees. Condensation is removed from the system mainly through the Condensate Collector located at the base of the chimney, with an additional Duct Drain located on the end of the manifold. Some condensation can pass back through the appliance to the condensate sump where it will be pumped to a suitable drain. Where two or more appliances are being vented into a common manifold as detailed above, careful consideration must be given as to the internal diameter of both the manifold and chimney to ensure that the flow dynamics are such that the system will adequately discharge the products of combustion to atmosphere. Where required SFL can undertake full sizing calculations for the system using the latest flow modelling software to the required standards.

iSize
Chimney Sizing Made Simple

SFL iSize is our in-house computerised chimney sizing software that models the flow dynamics and thermal properties of the proposed system to ensure that the design adequately vents the products of combustion to atmosphere and the design complies with BS EN 13384 parts 1 & 2. iSize is a professional licensed package and not a marketing tool. However if you are a Building Services Consultant, Specialist Chimney Company / Installer, then you may qualify for a free user license. For further information please contact your local Area Sales Manager, who will discuss further your requirements.

--	--	--

Complementing products

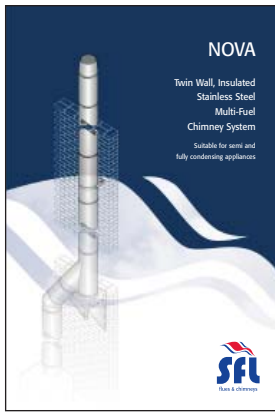

Nova SM is a twin wall insulated multi-fuel stainless steel chimney system covering an internal diameter range from 100mm to 350mm. Nova is also suitable for positive pressure and condensing applications.

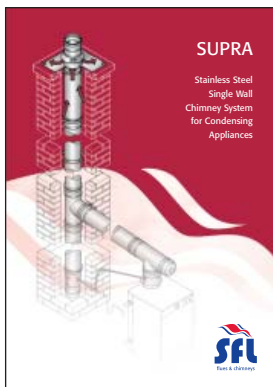

Supra is a single wall grade 316L stainless steel chimney system suitable for positive pressure and condensing applications. Supra covers an internal diameter range from 80mm to 600mm.

The information contained in this brochure was accurate at the date of publishing. However the company reserves the right to introduce at any time modifications and changes of details as may be necessary. To avoid any misunderstanding, interested parties should contact the company to confirm whether any material alterations have been made since the date of this brochure.



FM657622



0086 - CPD - 496040



flues & chimneys
Confidence In Quality

UK Sales and Customer & Export Services

SF Limited, Pottington Business Park, Barnstaple, Devon EX31 1LZ

Tel: 01271 326633 Fax: 01271 334303

www.sfchimneys.com info@sfchimneys.com